



Innovations in Action

ADVANCED COOLING TECHNOLOGIES, INC.

ACT-HPC SERIES HEAT PIPE COOLERS SEALED ENCLOSURE COOLING INSTALLATION GUIDE



HPC-80



HPC-50



HPC-15



HPC-40



- SEALED ENCLOSURE COOLERS KEEP THE INSIDE OF YOUR ENCLOSURE FREE OF DIRT & DEBRIS
- NEMA 1 2, 4, 4X AND 3R MODELS AVAILABLE
- OPERATING VOLTAGES: 12VDC, 24VDC, 48VDC, 115 VAC AND 230VAC
- DUAL AXIAL BALL BEARING FANS FOR YEARS OF MAINTENANCE FREE OPERATION
- 1-YEAR WARRANTY

CAUTION

BEFORE INSTALLING AND USING THE ACT-HPC PRODUCT, IT IS IMPORTANT THAT THIS MANUAL BE READ AND UNDERSTOOD THOROUGHLY

ACT-HPC Series Heat Pipe Cooler Operation

The ACT Heat Pipe Cooler (HPC) is a conduction based enclosure cooling product that is available in four sizes to address a large range of enclosure sizes and heat loads. The HPC design features a heat pipe core with a flange in the center for mounting to the wall of an electrical enclosure. The heat pipes transport heat from the inside of the enclosure to the outside ambient through highly effective two-phase heat transfer within each pipe. The HPC-15 has 8 heat pipes, while the HPC-40 and HPC-50 each have 24 heat pipes and the HPC-80 has 48 heat pipes.

ACT-HPC units are designed to be mounted to the top surface of an enclosure. Side mount configuration is possible but there is a performance penalty when the HPC is installed this way. Installation requires a square cutout in the wall of the enclosure for the HPC to stick through. A bolt pattern around the perimeter secures the HPC to the enclosure and compresses the perimeter gasket, making a seal that prevents dirt or water from entering the cabinet.



Typical Installation location for an ACT-HPC-15 unit

ACT-HPC units operate by exchanging the heat from the air inside of the electronics enclosure with the ambient air outside of the enclosure without allowing the two air streams to mix. In figure 1 the graphic depicts the airflow direction for an HPC-40 unit.

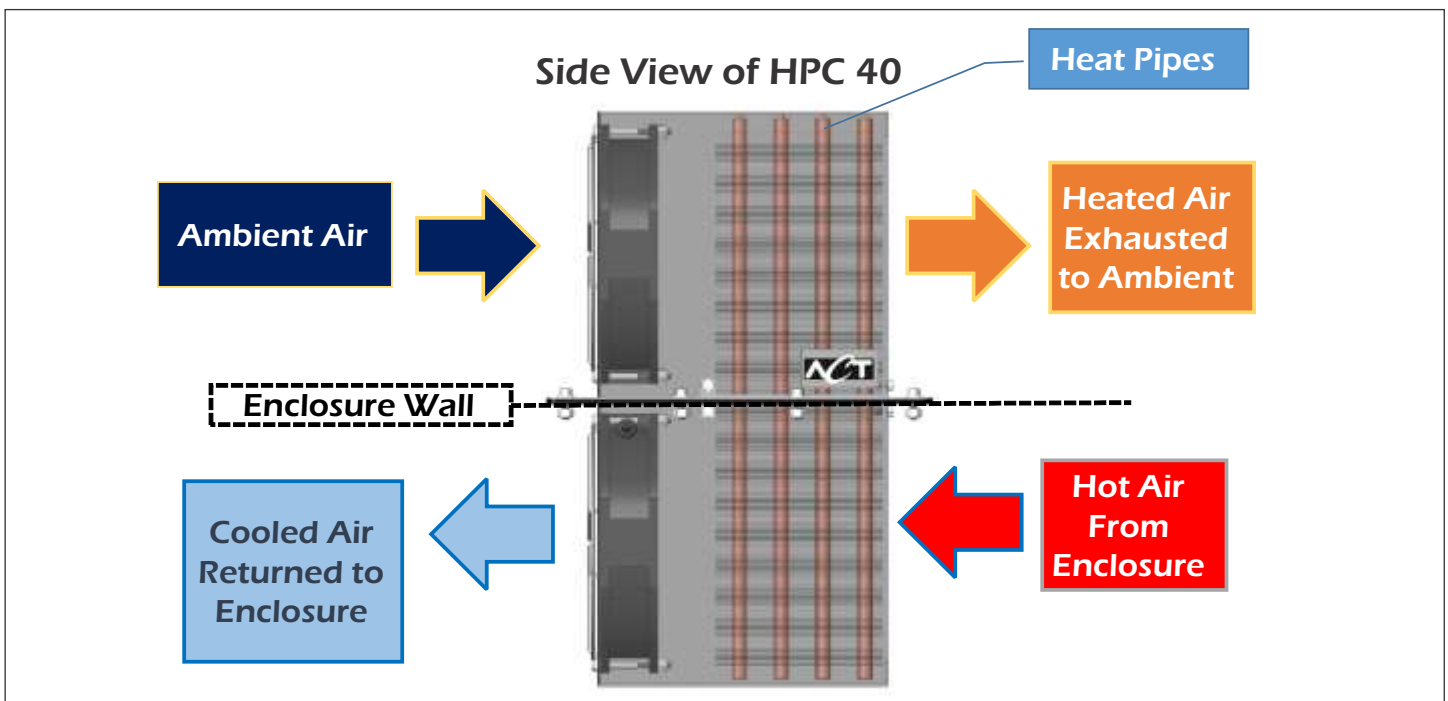
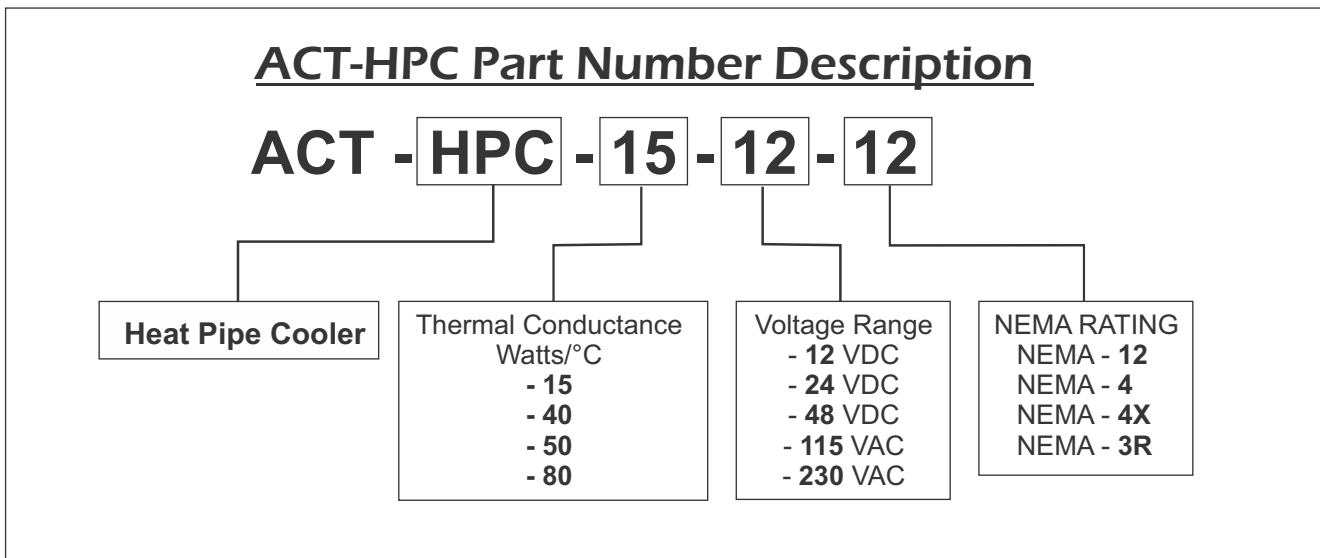

Figure 1 : Side View of ACT-HPC-40 with arrows showing the airflow patterns of the internal and external air streams

ACT-HPC Series Heat Pipe Cooler Operation

The number that has been assigned to each of the ACT-HPC models corresponds to its thermal conductance in Watts/°C. For example, the ACT-HPC-15 is capable of dissipating 15 Watts of heat for every 1°C temperature difference between the inside air and the ambient air outside of the enclosure. The ACT-HPC-80 is capable of dissipating 80 Watts of heat for every 1°C temperature difference.

If an electrical cabinet has 1000W of internal heat, a maximum ambient condition of 40°C and a maximum cabinet air temperature of 60°C, the enclosure designer needs to specify a heat exchanger with greater than $[1000W/(60^{\circ}-40^{\circ}C)] = 50W/^{\circ}C$ conductance to keep the cabinet air from exceeding the 60°C limit. A complete product part number description can be reviewed below.



Product Warranty Policy

In the event of a performance issue, please contact the factory before troubleshooting the unit. Removal of the cover prior to contacting the factory will void the warranty. ACT provides a one-year warranty against defects in materials and workmanship in its products. For more information, refer to ACT's exclusive terms and conditions of online sales at:

www.1-ACT-com/enclosure-cooling/act-exclusive-terms-conditions/

All returns must be pre-approved and issued an RMA number. The RMA number must be included in the box with the returned product documentation.

ACT-HPC Series Models, Capacities & Dimensions

Part Number	Thermal Conductance Watts/°C	Thermal Capacity Watts @ 20°C ΔT	Weight (lbs.)	H (in")	W (in")	D (in")	Insertion Depth (in")	Mounting Plate (in")
ACT-HPC-15	15.0	300	7.0	11.30	5.145	5.0	5.60	6.75 x 6.75
ACT-HPC-40	40.0	800	17.0	15.00	7.645	7.5	7.40	10.0 x 10.0
ACT-HPC-50	50.0	1,000	27.0	22.00	7.650	7.5	10.90	10.0 x 10.0
ACT-HPC-80	80.0	1,600	37.0	15.00	15.150	7.5	7.40	10.0 x 17.5

ACT-HPC Series Features and Options

Environment.....	Indoor or Outdoor Use
Electrical Configuration.....	115 VAC, 230VAC, 12VDC, 24VDC and 48VDC - AC units arrive with 6ft. long 3-pronged plug - DC units arrive with bare lead wires
NEMA Options.....	12, 3R, 4 and 4X (UL50E Certified)
Fans.....	UL Listed 4.0" & 6.0" ball bearing type axial fans (dry & wet locations)
Mounting Plate.....	304 Stainless Steel
HPC Housing.....	Powder coated aluminum, Optional: stainless steel
Enclosure Mounting Options.....	Top (best performance), side, front or back (derated performance), contact ACT or use our Online Selection Tool to easily select models
Other Options.....	Rain guards and removable filters
Approvals.....	cUL:115VAC units. cUR:12VDC,24VDC, 48VDC, 230VAC units

ACT-HPC Maximum Current Draw By Model

	Model	ACT-HPC-15*	ACT-HPC-40	ACT-HPC-50	ACT-HPC-80
NEMA Rating	Voltage	Maximum Operation Current (Amps)	Maximum Operation Current (Amps)	Maximum Operation Current (Amps)	Maximum Operation Current (Amps)
(4, 4X, 3R)	12VDC	1.80	3.60	3.60	7.20
12	12VDC	1.80	3.90	3.90	7.80
(4, 4X, 3R)	24VDC	0.92	1.64	1.64	3.28
12	24VDC	0.92	1.66	1.66	3.32
(4, 4X, 3R)	48VDC	0.52	0.88	0.88	1.76
12	48VDC	0.52	0.92	0.92	1.84
(4, 4X, 3R, 12)	115VAC	0.60	0.72	0.72	1.44
(4, 4X, 3R, 12)	230VAC	0.28	0.38	0.38	0.76

ACT-HPC Series Installation Procedure

Pre-Installation Procedure:

Check for any damage to the box that the unit was shipped in. Remove all shipping foam and inspect the unit for external damage. Any sign of damage should be documented and reported to the carrier.

Assuming there is no visible damage, stand the unit up vertically so that both air streams are clear and plug the unit into a power source to verify that the internal and external fan(s) are operational. After successfully completing this quick test, the ACT- HPC unit is ready for installation.

The following assembly procedure details the installation of a sealed enclosure cooler to the wall of an electronics enclosure. The procedure applies to each of the products in the ACT-HPC line. The three Heat Pipe Cooler models (ACT-HPC-15, ACT-HPC-40, ACT-HPC-50 and ACT-HPC-80) are very similar in design and therefore have a similar assembly process. The major difference between the models is the size of the cutout in the wall of the enclosure and the hole pattern used to fasten the enclosure cooler to the wall of the enclosure.

The size and weight of the ACT-HPC-15, 40 and 50 models are manageable for one person to install. The ACT-HPC-80 is larger in size and heavier, so it is recommended that two people work together to install the unit.

Step 1: Determine the location of the cooler on the enclosure. For best performance, the ACT-HPC models are installed at the top of the cabinet or they can be side mounted with a slight drop in performance (typically about 10% - 15% less). Ensure that you have at least 6" of open space between the fan intake and the next closest enclosure or wall. When you have decided on a location, use masking tape to outline the square cutout, (see figure 2). The cutout dimensions are shown in the drawings in [Appendix A](#) and are available for download in .DXF or .STEP file format from the ACT-Enclosure Cooling Resources area of the ACT website. Start by using a hole saw to establish holes in each corner. Use a reciprocating saw to make straight cuts between the corner holes, using the masking tape as a reference edge and to minimize damage to the enclosures surface.

CAUTION

The risk of fire, electric shock or injury exists when installing, cleaning or performing maintenance on the ACT-HPC unit. **ALWAYS DISCONNECT** the ACT-HPC from the power supply during installation or prior to servicing.

WARNING

TO REDUCE THE RISK OF FIRE, ELECTRIC SHOCK OR INJURY, PLEASE OBSERVE THE FOLLOWING:

Installation work and electrical wiring must be done by qualified person(s) in accordance with all applicable codes and standards, including fire-rated construction.

ACT-HPC Series Installation Procedure

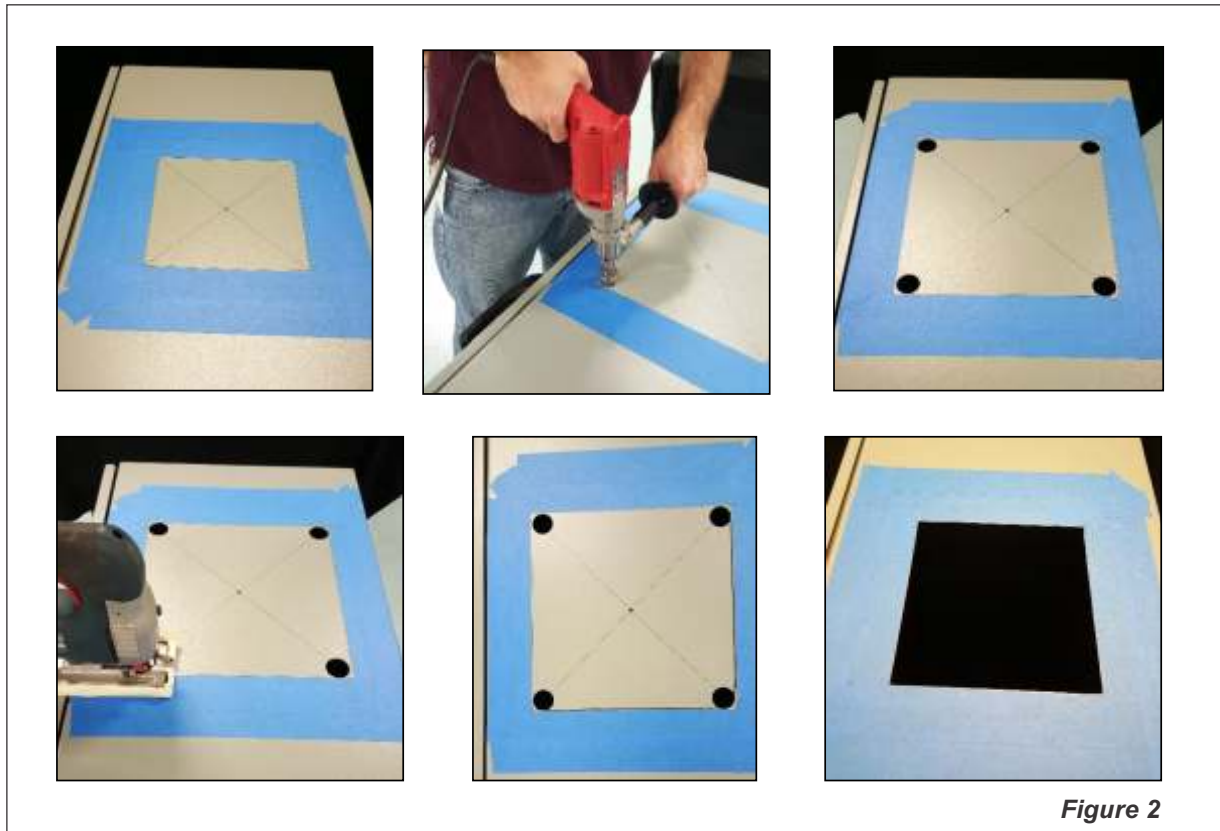

Step 2: Use the edge of the cutout as a reference edge and plot out the perimeter hole locations according to the drawing shown below in *Appendix A*. Once the holes have been marked, drill the remaining mounting holes at the correct location.

Step 3: Deburr the edges of the cutout using a file. Deburr the holes using a countersink bit.

Risk of injury

Carefully deburr all drilled holes and cut-outs to prevent injuries caused by sharp edges.

Step 4: Remove the masking tape and clean any excess cutting oil from the surface/internals of the enclosure.

Step 5: Place the HPC in position on the wall of the enclosure. The electrical cord should be passed through the opening in the enclosure prior to inserting the HPC body through the cutout. The ACT-HPC should be oriented so the gasket contacts the outside surface of the enclosure. Ensure that the gasket surface is free of dust, dirt, and imperfections and that it makes consistent contact with the external surface of the enclosure.

Step 6: With the HPC held in place, install the fastening bolts around the perimeter flange of the ACT-HPC. The ACT-HPC-15, 40 and 50 models have 8 bolts and the ACT-HPC-80 version has 18 bolts. Make sure the sealing washer is properly located on the bolt as shown in *figure 3*. The sealing washer is meant to seat on the external face of the ACT-HPC (the face opposite the gasket).

ACT-HPC Series Installation Procedure

Caution

ACT recommends applying an anti-seize lubricant to the threads of the mounting hardware to prevent galling.

NOTE: The size and weight of the ACT-HPC-15, 40 and 50 models are manageable for one person to install. The ACT-HPC-80 is larger in size and heavier, so it is recommended that two people work together to install the unit. Install sealing gasket prior to mounting and prepare perimeter bolts with sealing washers as shown in *figure 3*.



Figure 3: Perimeter bolt with sealing washer and locking nut (left) perimeter bolts installed on enclosure after being torqued down. Bottom left displays the sealing gasket for an ACT-HPC-15 model.



Step 7: Torque the perimeter bolts evenly, alternating between bolts in a diagonal pattern so that the sealing gasket is compressed in an even fashion. Ensure that every bolt is torqued to at least 20 in-lbs.

ACT-HPC Series Installation Procedure



Figure 4: ACT-HPC-15 installed on the top of an enclosure.

Step 8: Provide electrical power to the heat sink unit and verify that all fans are functioning properly. Double check that the fan air intake is clear and that no enclosure walls or hardware are within 6.0" of the intake or exhaust portion of the heat exchanger.

CAUTION

ACT-HPC units are available in a wide range of operating voltages. Make sure the supply voltage matches the stated voltage on the ACT factory label. An improper input voltage connection will void the product's warranty



Figure 5: An ACT-HPC installed on an electrical enclosure with the door open

ACT-HPC Series Installation Procedure

CAUTION

Do not operate the ACT-HPC units without the fan guard properly in place.

CAUTION

For proper operation make sure that the fan air intake is clear and that no enclosure walls or hardware are within 6.0" of the intake or exhaust portion of the ACT-HPC heat exchanger.

Step 9. (Optional): If a rain hood or filter kit has been selected, it is recommended that the rain hood or filter kits be installed prior to mounting the ACT-HPC to the enclosure wall. The rain hood or filter kit comes with four (4) self tapping screws. Simply place the rain guard over the fan opening as shown in below, mark each of the hole locations, temporarily remove the rain hood or filter kit and drill a pilot hole (0.136" diameter) at each mark. Finally, place the rain hood or filter kit in the original location and fasten it to the cover using the four self tapping screws.

You have successfully completed the installation of the ACT-HPC unit.



ACT-HPC Side
Mounted Rain Hood



ACT-HPC Top
Mounted Rain Hood

Figure 6 : An ACT-HPC-40 with optional rain guards for side or top installation. See Appendix B for all Rain Guard, Fan and Filter Options

APPENDIX A: ACT-HSC Heat Sink Cooler Series - Dimensions & Installation

ACT-HPC-15

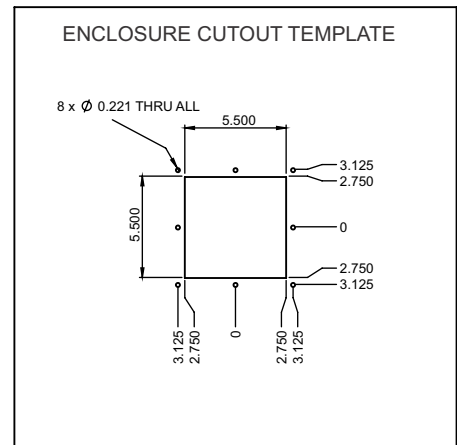
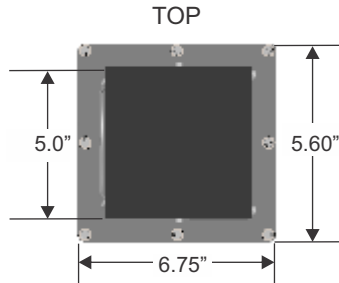
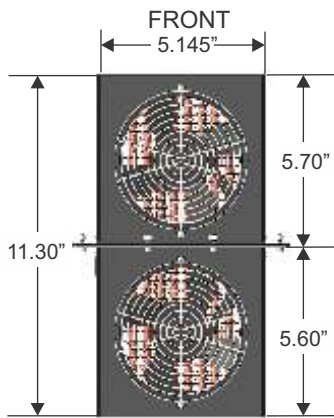

ACT-HPC-40

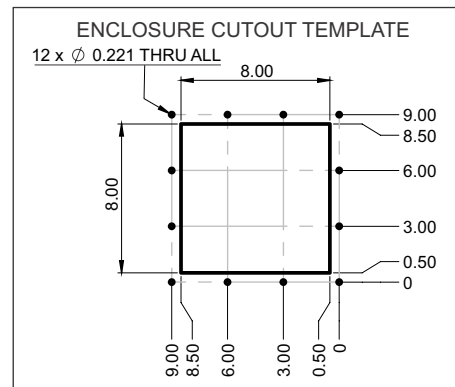
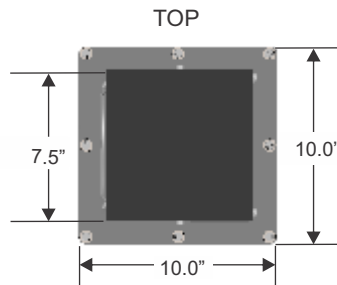
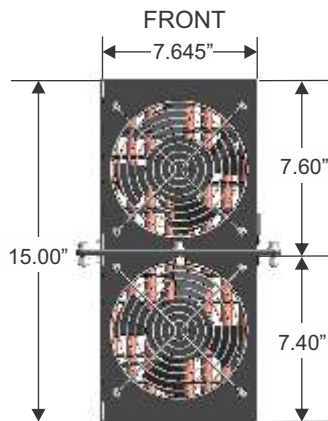

ACT-HPC-50

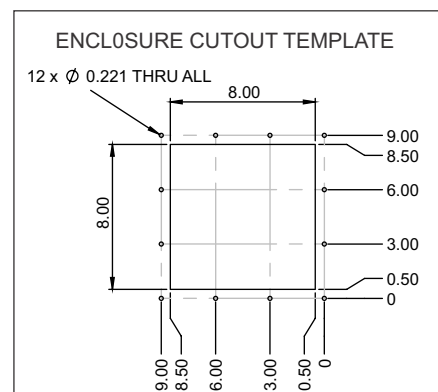
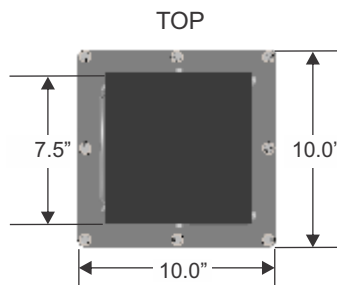
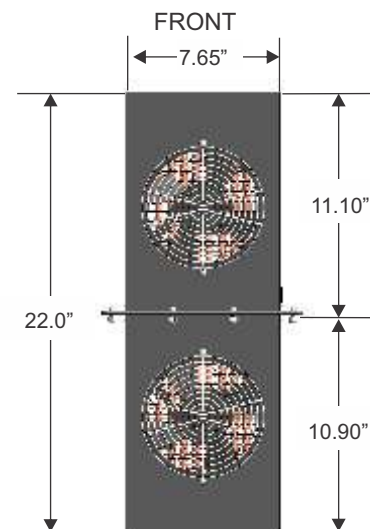

ACT- HPC Heat Pipe Cooler Series - Dimensions & Installation cont...

ACT-HPC-80

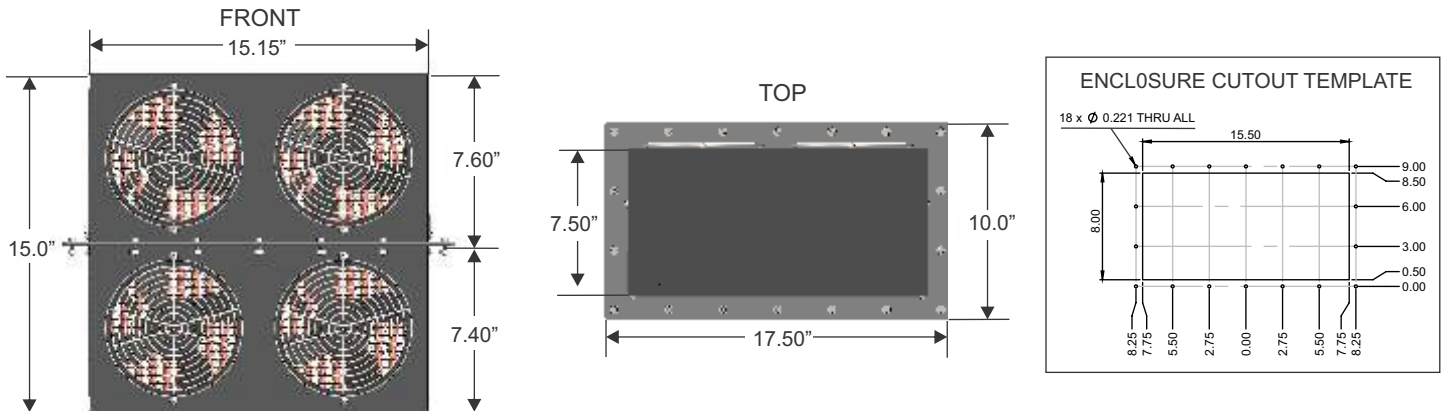

APPENDIX B: ACT-HPC Replacement Fans, Rain Hoods and Filter Kits

Ordering an ACT-HPC Replacement Fan



ACT - HPC - 15 - 12 - 12 - I

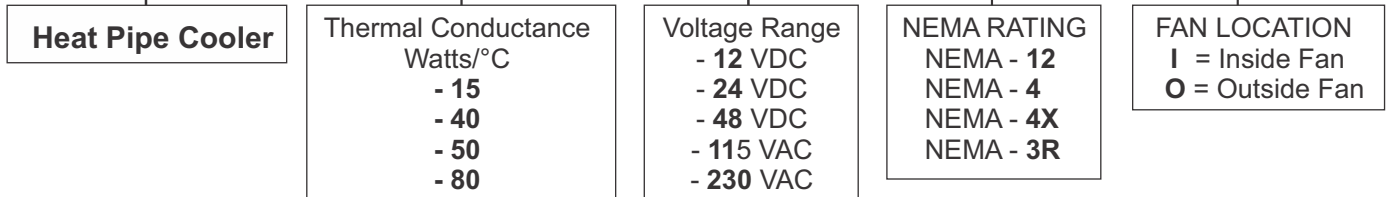

To order any of these items please visit:

<https://www.1-act.com/product-category/act-hpc-heat-pipe-cooler-series-sealed-enclosure-cooling/>

Ordering an ACT-HPC Rain Hood

ACT - HPC - 15 - 3R - SM - Hood

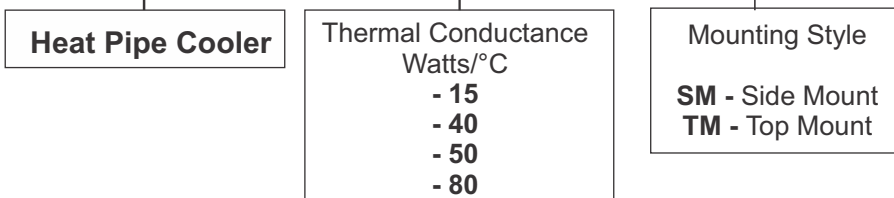

To order any of these items please visit:

<https://www.1-act.com/product-category/act-hpc-heat-pipe-cooler-series-sealed-enclosure-cooling/>

Ordering an ACT-HPC Filter Kit

ACT - HPC - 15 - Filter Kit

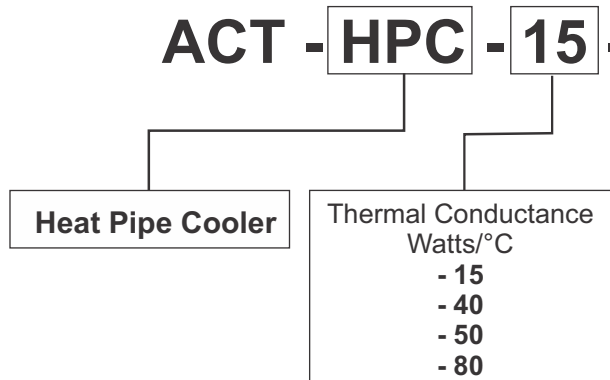

To order any of these items please visit:

<https://www.1-act.com/product-category/act-hpc-heat-pipe-cooler-series-sealed-enclosure-cooling/>