

A Systems Study of a Stirling Converter based Space Nuclear Power System

Joseph VanderVeer* and Robert Sievers†
Teledyne Energy Systems, Inc., Hunt Valley, MD, 21031

Michael Amato‡ and Maurice White§
American Super Conductor, Richland, WA, 99354

William Anderson¶
Advanced Cooling Technologies, Lancaster, PA, 17601

A study of several systems of a Stirling converter based nuclear power system was performed. The study included the Stirling converter hot side interface, Stirling converter cold side interface, and the generator heat rejection system. Analysis indicates a one-size-fits-all approach does not work for system components. The hot side interface options decrease the temperature drop from the baseline of 80 °C down to 8 °C. However, the hot side interface has a trade-off of development risks (time and money) vs flight risks (more development, but more robust system overall), which needs to be performed for the available resources during development. The cold side interface has little influence to select either heat pipe or pumped coolant and the option should be left open for the heat rejection system. The heat rejection system study pushes the simpler design fixed heat pipe design for the smaller scale systems, but tends to a more complex pumped coolant wing design for the larger scale systems. Performance for the various options is similar, but size, robustness, and risk are the differentiating factors.

I. Nomenclature

A	=	Area
ASC	=	Advanced Stirling Converter
DRPS	=	Dynamic Radioisotope Power System
EDL	=	Entry, Decent, and Landing
FISC	=	Flexure Isotope Stirling Converter
FSC	=	Fission Stirling Converter
GPHS	=	General Purpose Heat Source
HEU	=	Highly Enriched Uranium
KRUSTY	=	Kilowatt Reactor Using Stirling Technology
MMRTG	=	Multi-Mission Radioisotope Thermoelectric Generator
Q	=	Heat
RTG	=	Radioisotope Thermoelectric Generator
TDC	=	Technology Demonstration Converter
T_{surf}	=	Surface temperature
T_{∞}	=	Absorbing temperature
ε	=	Emissivity
η_{fin}	=	Fin efficiency
σ	=	Stefan-Boltzmann constant

*Thermal Design Engineer, Thermal Engineering.

†Director, Advanced Energy & Power Systems.

‡Principal Investigator.

§Advisory Engineer.

¶Chief Engineer.

II. Introduction

LARGE scale (1-10 kW electrical) solar independent space power systems would be beneficial to many long term goals of space exploration such as missions to the Moon, Mars, or deep space. A potential approach to achieve this lofty goal is to utilize free piston Stirling convertors paired to a small fission reactor. Significant preliminary work has been invested as a proof of concept from both NASA and DOE e.g. Mason [1], Gibson et al. [2].

Nuclear space power has often been restricted to radioisotope thermoelectric generators (RTG's). They are extremely reliable systems which can and have operated for decades without any major issue. However, RTG's are saddled with low system efficiency. The current state of the art is the multi-mission radioisotope thermoelectric generator (MMRTG) which is rated for 110 W electrical output at 6% thermal-to-electrical conversion efficiency [3]. Stirling convertors greatly improve upon the low efficiency problem of RTG's, but have moving parts and therefore have more reliability concerns than RTG's. To increase the reliability of Stirling convertors, redundant convertors can be utilized, but their efficiency drops for a constant heat source like a general purpose heat source (GPHS). This problem can be entirely mitigated by utilizing a controllable heat source like a small reactor. As an example, the heat pipes running from the reactor to the convertors could be variable conductance heat pipes tuned to transfer heat to the Stirling convertors at differing temperatures. This would allow minimal numbers of Stirling convertors to be operational when the reactor is at lower power. Therefore pairing Stirling convertors with a small reactor via heat pipes allows for the high efficiency and redundancy in a more controllable system.

There are still significant challenges to overcome before a fully viable system is possible, but none at this time seem to be insurmountable. A few of the challenges to be discussed in this paper are: Stirling convertor hot side interface, Stirling convertor cold side interface, and the generator's heat rejection system. A challenge worth mentioning, but not discussed further here, is the reactor radiation shielding. The following topics are meant to give an overview of the challenges with a few potential options and some discussion with risks and risk mitigation. Each topic is discussed more or less independently, but this does not affect the overall goal of describing the challenges, proposing possible solutions to them, and then discussing some potential open risks.

A. Heat Flow Diagram

Figure 1 displays a diagram of the heat flows within the system. The heat source is a highly enriched uranium (HEU) reactor, which is cooled by sodium heat pipes. The heat pipes move the heat to the Stirling convertor hot side interface. The Stirling convertor generates electricity and rejects the waste heat through the cold side interface to the heat rejection surfaces via either heat pipes or a pumped coolant.

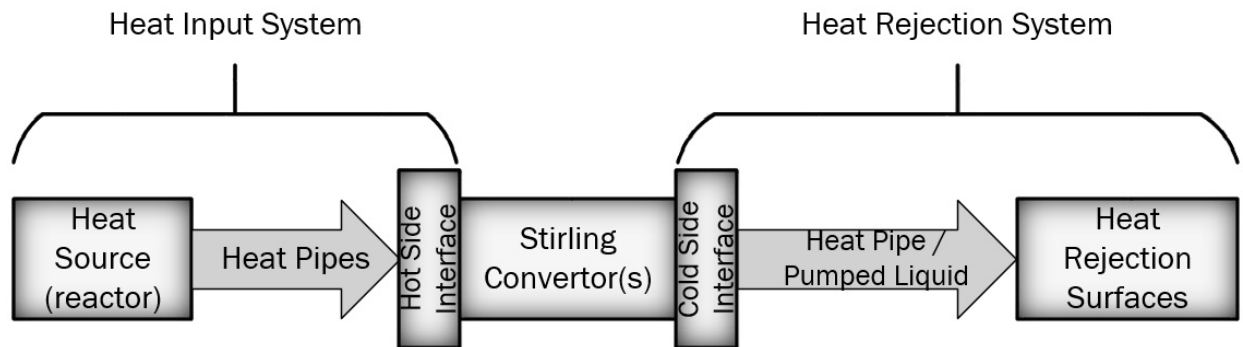

Fig. 1 System Heat Flow.

B. Design Constraints

With a system as complex as a space nuclear power system it is expected to have many design requirements and constraints. A list of the some of requirements that are both important and relevant to this discussion are listed below.

- 1) The complete system shall fit within an available rocket faring.
- 2) The generator shall survive launch conditions in an off state.
- 3) The generator shall operate in Earth, Mars, Moon, and deep space environments.
- 4) The generator shall operate for a minimum of 10 years.

5) The condensing side of the reactor heat pipes shall operate at a temperature between 750 °C and 800 °C

The first item impacts the heat rejection system as the surfaces can become very large for the higher powered systems. The second requirement aids in the simplicity of the convertor designs, e.g. a dynamic radioisotope power system (DRPS) needs to be robust enough to not have issues while operating during launch and EDL. The third impacts heat pipe designs and it requires both gravity and zero gravity conditions. A generator life is a minimum of 10 years means the system must have redundancy built in. The last requirement drives the desire to utilize liquid sodium in the hot side heat pipes as they are ideally suited for that temperature range.

III. Reliable Stirling Convertor

Development of a reliable convertor starts with the most reliable convertor designed to date and attempts to make it more reliable. The technology demonstration convertor (TDC) is the most reliable Stirling convertor to be tested to date. The TDC has 4 units surpassing 100 kh and at least one unit with over 110 kh. One of the units was disassembled for signs of wear and tear. This information was utilized to make future designs more reliable.

Two potential space flight designs emerged from analyzing the TDC. The first is a small 70 W electrical unit designed to be integrated into a DRPS[4]. The second is a larger 1352 W electrical convertor designed to be part of a 1-10 kW kilowatt scale system. An overall view of the larger convertor known as the Fission Stirling Convertor (FSC) is shown in fig. 2.

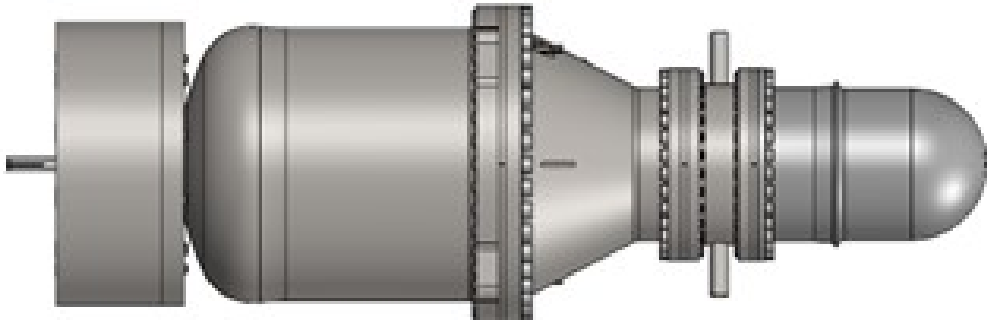

Fig. 2 Fission Stirling Convertor (FSC) 1352 W electrical output.

One of the key driving contributors which made the TDC so reliable is the utilization of flexures to keep all of the moving components from rubbing and therefore friction and degradation free. A representation of how the flexures keep components aligned is shown in fig. 3.

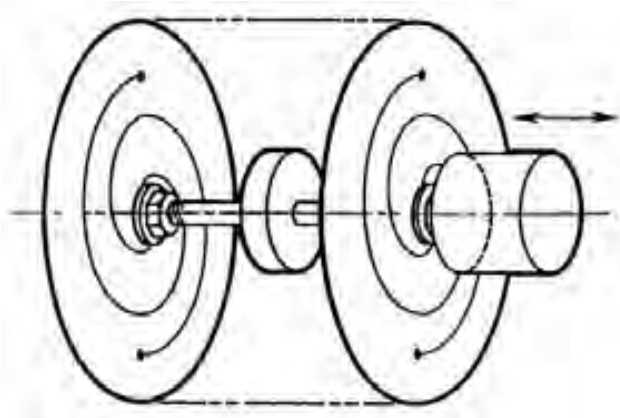

Fig. 3 Simplified Example of a Flexure Supported Linear Alternator.

IV. Converter Hot Side Interface

Due to many factors, notwithstanding the radiation emitted from the small reactor, liquid metal heat pipes are the only practical method of moving the heat from the reactor to the Stirling convertors. Heat pipe design is critical and integration with the heater head of the convertor has been troublesome in the past. A simple analysis of the Advanced Stirling Convertor (ASC) work is performed to compare with three new potential designs. Each of the new designs has progressively less temperature drop, but at increased complication and potentially increased risk. The larger convertor used in this analysis requires 6 heat pipes to transfer enough heat and ensure reliability.

A. Baseline

The kilowatt reactor using Stirling Technology (KRUSTY) technology demonstration test utilized a poorly designed hot side heat pipe to Stirling convertor interface. The poor design was due to a design restriction which prohibited brazing, welding, or otherwise permanently modifying the Stirling convertors used for the test. The issues were more economical than engineering related.

A diagram of the baseline hot side interface is shown in fig. 4. The light gray tubes are the heat pipes from the reactor to red heat pipe condensing section. The dark gray plate is nickel meant to interface with eight Stirling convertors. The light blue tubes are regions for the non-condensing gases to collect. A key reason for this design and part of the reason the heat transfer is poor is that the Stirling convertors included a heat collector designed to accept heat from a GPHS block.

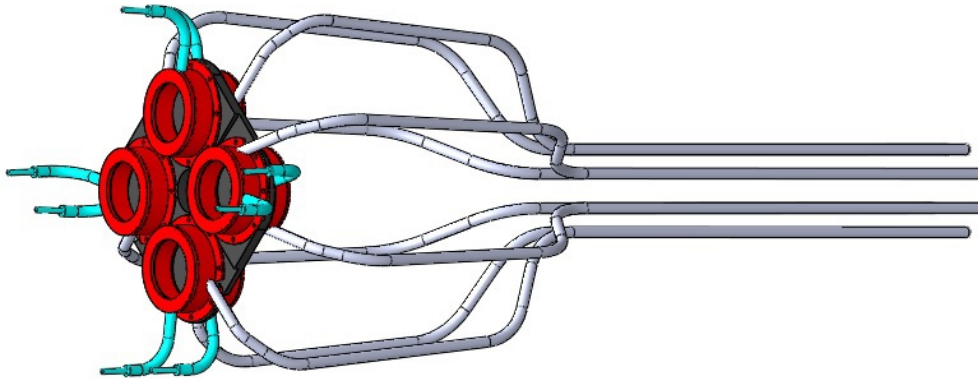

Fig. 4 Baseline hot side interface [5].

The temperature drop between the liquid sodium of the heat pipes and helium of the convertors was approximately 80 °C. The ASC was designed to accept the heat from 1 GPHS block or 250 W. However, the Stirling convertor being utilized is substantially larger than the ASC and requires 3790 W input. With a thermal conductance of 3.125 W K⁻¹ this design results in a hypothetical 1216 °C temperature drop*.

B. Brazed Heat Pipes

Heat transfer theory says to reduce the temperature gradient with a constant heat flux the distance traversed must be reduced or the thermal conductivity must be increased. Following this simple mantra the first design reduces the distance and removes several materials. In this case the condensing region of the heat pipes get brazed directly onto the heat input region of the convertor. While this approach has a larger difference in temperature than the following two options the increase in manufacturability of this option may make it the best candidate. Figure 5 is a diagram of the hot side interface with the brazed heat pipe option.

Sage modeling used to model the convertor and integrated heat pipe option results in a thermal conductance of 140.4 W K⁻¹. The braze option is a slight deviation upon the integrated heat pipe option with the braze and an extra metal wall separating the two working fluids and results in an adjusted thermal conductance of 125.6 W K⁻¹. With the expected heat flow this results in a temperature drop of 30 °C, which is a remarked improvement over the baseline.

*With a peak temperature of 750 °C it is obvious this cannot occur, but serves as a comparison point for improvement



Fig. 5 Brazed Hot Side Interface.

C. Integrated Heat Pipes

Continuing with the theme of removing as much material between the two working fluids, the integrated heat pipe option eliminates one of the walls and the braze from the brazed heat pipe option. Figure 6 is a representation of the thermal interface for the integrated heat pipe option. The temperature drop across the interface is essentially an output of the Sage model as previously described. The temperature drop in this case is 27 °C, which results in a thermal conductance of 140.4 W K⁻¹. This is slightly better than the brazed option as to be expected.

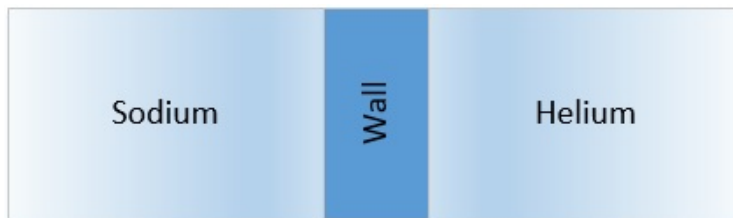

Fig. 6 Integrated Heat Pipe Hot Side.

D. Integrated Heat Pipes with Helium Tubes

The integrated heat pipes with helium tubes takes a step back from the remove material theme of the prior options. This design utilizes 2 major changes: the helium heat exchanger is replaced by a set of tubes, and those tubes are submerged in liquid sodium. The liquid sodium enables the heat pipe to interface with a single wall rather than the complex geometry of the tubes. The impact here is that the condensing sodium and helium have a dramatically increased surface area. Figure 7 shows the interface diagram with the center sodium being non-condensing. While the interface diagram is useful a layout diagram (shown in fig. 8) is significantly more useful. Here one can see that heat pipes can be located both on the outside and inside of the ring of helium filled tubes. There are 50 tubes shown in the diagram with opposite pairs connected as to facilitate thermal smoothing in case one of the 6 heat pipes were to fail.



Fig. 7 Integrated Heat Pipes with Helium Tubes.

The surface area of the helium tubes increases by a 25%, while the surface area for the condensing sodium increases by essentially double. Through first order heat transfer analysis a single tube has a thermal conductance of 9.4 W K⁻¹, which results in a temperature drop of approximately 8.0 °C. This hot side interface is the best hot side interface for a few reasons: temperature drop is the lowest, enables thermal smoothing should a heat pipe fail, and enables a thinner hot side (due to the smaller diameter of the tubes). These increased benefits are at a cost of a significantly more complicated component, with a few more failure modes. As was stated earlier, each option has a progressively lower temperature drop, but at an increase in potential risk.

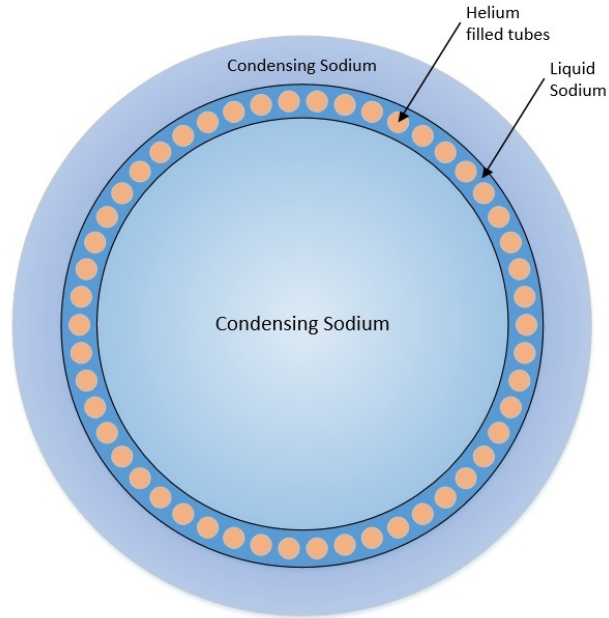

Fig. 8 Integrated Heat Pipes with Helium Tubes Layout.

V. Convertor Cold Side Interface

The cold side interface is less problematic than the hot side. This is primarily due to the significantly lower temperatures involved ($150\text{ }^{\circ}\text{C}$ vs $750\text{ }^{\circ}\text{C}$) and the heat flow is approximately 70% of that of the hot side. There are two primary options for cooling the cold side: pumped coolant and heat pipe. Both options have pros and cons and neither is a clear winner.

A. Pumped Coolant Cold Side Interface

The pumped coolant option utilizes a high boiling point and low freezing point liquid which is pumped through a loop. The coolant passes through a narrow channel heat exchanger within the convertor to extract the waste heat. Figure 2 shows a configuration setup to accept pumped coolant. This option has a thermal advantage over the heat pipe option (purely for manufacturing and packaging reasons) of $4\text{ }^{\circ}\text{C}$ vs $17\text{ }^{\circ}\text{C}$. The coolant can get closer to the helium than the condensing surface of the heat pipe can without significantly redesigning the cold side of the convertor.

The pumped system does not have a realistic restriction as to how far the heat rejection panels can be from the convertors. This has the potential benefit of utilizing the waste heat on-board a space craft, in lunar/martian bases, or for space based industrial applications. At $100\text{ }^{\circ}\text{C}$ this waste heat could be used for heating a space based facility. A potential need for a larger kilowatt device is the electrolysis of water [2], on both the moon and mars the water to do this is frozen and would need to be warmed up to liquid temperatures. As water has a very high specific heat and high heat of fusion utilizing this waste heat to melt the ice first is an excellent way to utilize waste energy rather than utilizing electricity to do so.

Pumped systems also have no restriction on orientation/ gravity concerns that a heat pipe does (although with the hot side required to be heat pipes this may be less of an issue).

The major drawback to the pumped coolant option is of course the pump part of the system. The pump(s) are a failure mode which will require backups for such a system to be viable, adding weight to the overall system. The power required to drive the pumps is estimated to be $\approx 1\%$ of the total power output.

B. Heat Pipe Cold Side Interface

Heat pipes on the cold side of the system as already stated are a bit less thermally connected to the helium. This increases the cold side temperature drop, reducing the overall efficiency of the convertor slightly. The major benefits of the heat pipe option are that they're passive and don't have any pump requirements or balance of plant requirements. Heat

pipes do have a few challenges: orientation needs to be considered in a gravity field and in zero gravity environments heat pipes need to be carefully designed to enable enough fluid flow through wicking/capillary action to move the required amount of heat.

VI. Generator Heat Rejection System

Heat rejection on earth is a relatively simple task with all modes of heat transfer being options. In space applications, even lunar applications, radiation is the only practical means of rejecting waste thermal energy. For a smaller system (2 kW electrical or less) this generally is not too difficult, however, for the 10 kW electrical system the waste heat is a minimum of 22 kW, if maximum Stirling efficiency is assumed, but could be as high as 31 kW. This requires a substantial space-facing surface area to radiate to the surrounding environment. This can be challenging as the heat rejection system may need to be folded for flight applications. This does add significant challenges to the heat rejection system. As an example, assuming the maximum cold side temperature of 100 °C, a convertor efficiency of 35.7%, emissivity of 0.88, and a fin efficiency of 0.8 the resultant required surface area is 39.3 m². This also assumes the view factor to the environment is 1.0 for the entire surface. Each of the following 5 configurations are equivalent from a heat rejection point of view, but each has its own benefits and drawbacks, which will be discussed.

To calculate the surface area required a version of the Stefan-Boltzmann equation is used.

$$Q = \varepsilon\sigma A\eta_{fin}(T_{surf}^4 - T_{\infty}^4) \quad (1)$$

Where Q is the waste heat, ε is the emissivity of component radiating heat, σ is the Stefan-Boltzmann constant, A is the area, η_{fin} is the fin efficiency, T_{surf} is the emitting surface temperature, and T_{∞} is the absorbing surface temperature.

A. Fixed Heat Pipe Radiator Type 1

The first heat rejection system is a fixed heat pipe radiator and is shown in fig. 9. This design has been discussed previously by several papers such as Gibson et al. [2]. This design is simplest of all of the designs and for smaller power levels makes the most sense from a manufacturability and packaging point of view as will be shown shortly.

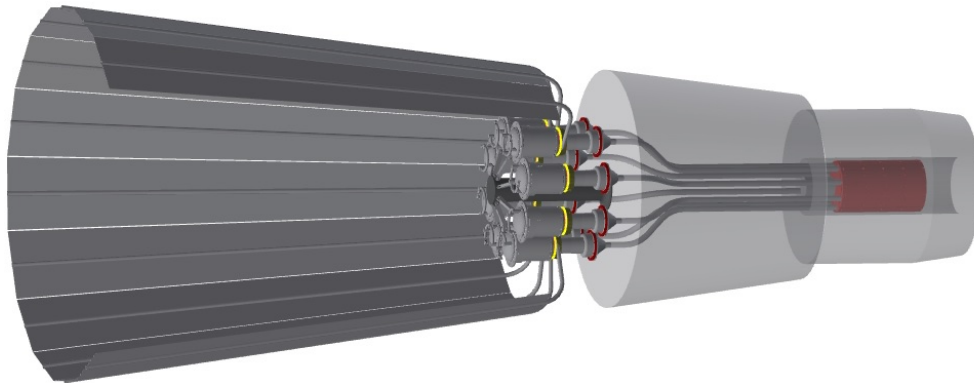

Fig. 9 Fixed Heat Pipe Radiator Type 1 [2].

Table 1 is a table of 2 operating conditions and 2 power configurations. The first two columns are of the lowest power configuration operating with a rejection temperature of either 150 °C or 100 °C. For this smaller configuration the radiator needs to be a maximum of 1.6 m. This is a quite reasonable size for space craft and fitting within the confines of a launch vehicle.

The last two columns are of the highest power configuration operating with a rejection temperature of either 150 °C or 100 °C. With a resultant height of either 6.7 m for the higher temperature and 11.5 m for the lower rejection temperature. The 6.7 m is somewhat reasonable given the high power output of the system. The 11.5 m is much less practical given the alternative approaches available. One could increase the diameter of the fins to decrease the required height and that is part of the premise of the second type of fixed heat pipe radiator. The fin efficiency used here is from measured data Lee et al. [6]. There is some argument for optimizing the fin efficiency of this style of heat rejection system however, it gives a good baseline for this study and will be used for all of the first 3 types of heat rejection systems due to the similarities between the systems.

Table 1 Performance of a Fixed Heat Pipe Radiator Type 1

Heat In	kW	4.3	4.3	43.3	43.3
Rejected Heat	kW	2.8	2.8	28	28
Rejection Temperature	°C	150	100	150	100
Emissivity		0.88	0.88	0.88	0.88
Fin Efficiency		0.58	0.58	0.58	0.58
Diameter	m	1.1	1.1	1.5	1.5
Height of Fins	m	0.9	1.6	6.7	11.5

B. Fixed Heat Pipe Radiator Type 2

A slight variation on the previous design, this design has increased fin diameter with the Stirling convertors located within the configuration of fins rather than below it. Figure 10 is a representation of a 1.3 kW electrical configuration with 100% redundant convertors. In this configuration with a diameter of 1.1 m the height of the fin is the same as it is in table 1. The advantage of this design is that the convertors are located within the radiating fins and therefore the system height can be reduced. At the lower power levels the advantage is reduced.

Figure 11 is a representation of a 13 kW configuration with 140% redundant convertors. This level of redundancy is not necessary, but it does demonstrate some options available. In this configuration the diameter of the radiating surface is 2.0 m with an extreme height of 8.2 m. With an increase in diameter to 3.0 m the height becomes a more manageable 5.8 m.

The fin efficiency of this design is likely to be higher than that of the previous design due to the arrangement of the convertors arrayed axially along the fin structure.

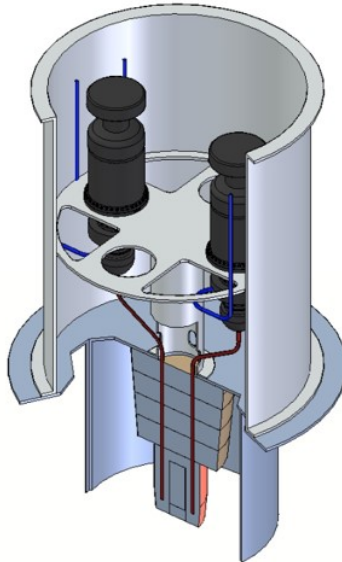

Fig. 10 Fixed Heat Pipe Radiator Type 2 1 kW Scale.

C. Deployable Heat Pipe Radiator

The deployable heat pipe radiator is fundamentally the same as the fixed heat pipe radiator type 1, but flattened into a disk when deployed. The folding nature allows for a much larger radiator to fit within the confines of a rocket faring. This also allows for the surface to be directly space facing when deployed on planetary surfaces. The folding nature adds an incremental risk to this type of arrangement.

For the 10 kW size the diameter of the deployed disk would need to be 8.3 m to adequately reject all of the necessary heat. This is making all of the same assumptions as the previous configurations.

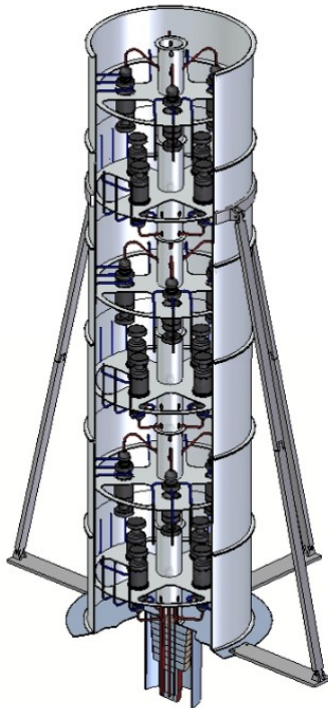

Fig. 11 Fixed Heat Pipe Radiator Type 2 10kW Scale.

D. Flexible Metal Tube Pumped Coolant Radiator

The flexible metal tube option is the largest departure from the other options. The other options utilize fixed or folding panels to radiate waste heat. This design utilizes multiple collapsed tubes with aluminum feathering to increase the radiative surface area. When ready to deploy the system utilizes the pumps to pressurize the tubing forcing the coil to unravel. For the largest design a total coil length of 600 m is required, which can be broken into 12 segments of 50 m each. This system easily allows for multiple redundant systems which can be kept in storage until needed. This method would only be viable on planetary surfaces as the floating coils could easily foul other parts of a spacecraft.

E. Deployable Pumped Coolant Radiator

The last option investigated is the deployable pumped coolant radiator, which is shown in fig. 12. The wings are designed to allow the fins to wrap around the central hub for stowing. Figure 13 shows a top down view with the wings stowed. The configurations shown in the figures are utilizing a larger 3.5 kW electrical output convertor, but the design is easily reconfigurable to support 10 of the 1.3 kW designs described earlier. To reject the 28.8 kW of waste heat needed the structure would need to have a wingspan of 10.0 m, but at a height of only 3.0 m it is much more practical in size. Not considered here is the usable area of the housing which could reduce the required wing span by 20%, but would complicate the heat rejection system.

A major benefit of this design over the previous designs is the very high utilization of both sides of the fin. All of the previous configurations had a significant portion of one side of the fin facing other fins, housing, or the surface of the Moon/ Mars. This enables a relatively compact design when stowed. This design could also support a loop heat pipe as a backup to the pumps should they fail or as the primary system with a little redesign.

F. Heat Rejection System Comparisons

To make comparisons easier the different heat rejection configurations are compared in this section. They will be compared at the 1 kW and 10 kW electrical power output levels. All of the configurations assume a maximum thermal inventory of either 4.3 kW or 43.3 kW. As the Stirling convertor’s nominal rejection temperature is 100 °C that will be kept the same in the comparison. Table 2 is the 1 kW comparison table. A quick review of the table shows that any of

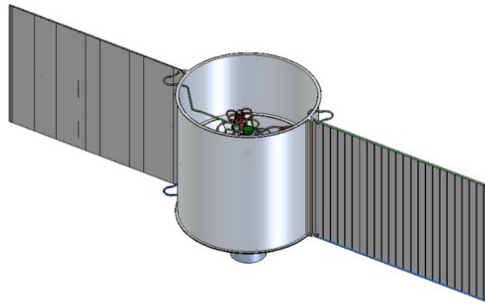

Fig. 12 Deployable Pumped Coolant Radiator.

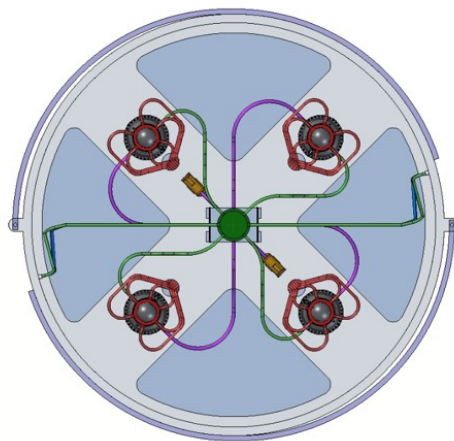

Fig. 13 Deployable Pumped Coolant Radiator in the Stowed Configuration.

the 5 options result in a reasonable system size for the power output. From this it can be quickly discerned that for the lowest power generators choosing the simplest and / or the most reliable makes the most sense, which is the fixed heat pipe design.

Table 2 1 kW Comparisons

Design		1	2	3	4	5
Fin Efficiency		0.58	0.58	0.58	0.5	0.8
Required Surface Area	m ²	5.4	5.4	5.4	6.3	3.9
Critical Dimension		Height	Height	Diameter	Length	Span
Critical Dim. Value	m	1.6	1.6	2.6	120	3.0

Table 3 is the 10 kW comparison table. Unlike with the 1 kW table a comparison of the data is less than revealing. The smallest critical dimension is the fixed heat pipe of the second type, but this is still a large structure. As described each of the designs have their pros and cons and a specific mission may drive towards one design more than another. From the point of view of packaging in a rocket faring the deployable pumped coolant design is the best option as the stowed design is the smallest.

Table 3 10 kW Comparisons

Design		1	2	3	4	5
Fin Efficiency		0.58	0.58	0.58	0.5	0.8
Required Surface Area	m ²	54.2	54.2	54.2	62.8	39.3
Critical Dimension		Height	Height	Diameter	Length	Span
Critical Dim. Value	m	11.5	5.8	8.3	1200	10.0

VII. Conclusion

Multiple options for the convertor hot side interface and the heat rejection system have been evaluated. The pros and cons have been discussed including some risks and risk mitigation options. An overview of the results are as follows:

Three options are presented for improving the convertor hot side interface of the KRUSTY system. It is clear that the issues with the original system were due to artificial restrictions and not an engineering flaws. Even the simplest solutions offered a temperature drop of more than half of the original system. The most complicated option offered a redundant heat pipe system with a temperature drop one tenth that of the baseline. The last option offers the most incentive to develop into flight hardware, but is more challenging with increased development risks. The choice as to which to go forward with would need to be based upon the scale of the system. The smaller scale system is likely able to accept more risk than the larger flight risks, while needing to avoid development risks. Conversely the larger scale system is likely to be able to accept more risk in development and less risk during flight. In either case a cost vs development risk vs flight risk analysis would need to be performed to determine the optimal path forward.

There are two options for the cold side interface: the pumped coolant or the heat pipe options. From an interface point of view the pumped coolant has a slight edge over the heat pipe since the design of the cold side makes it difficult to get the heat pipe condensing surface closer to the helium without modification (which is an option). For the cold side interface neither option is a clear winner. Selection of heat pipe versus pumped coolant should be made base upon the heat rejection system needs.

Five designs were investigated and as with the hot side interface the choice of which to utilize is based upon the electrical output needs of the system. For the smaller 1 kW system none of the systems have a clear advantage over the others and it should be clear that the simplest design is the preferred choice, which was the fixed heat pipe design. For the larger 10 kW system the heat rejection systems become very large and favor deployable systems. The deployable pumped coolant system has many advantages over the other options that make it the most favorable design. The deployable pumped coolant system can easily handle multiple redundant loops and an option for a loop heat pipe as a final back up. The system is also the smallest of all of the options when stowed, and can easily offer options to utilize the waste heat rather than rejecting it.

From initial investigation to final analysis it has been clear that the order of magnitude scale difference between the smallest kilowatt system and the largest make a single scaleable solution impractical. The difference in scales require the systems to become fundamentally different. For these reasons the brazed heat pipe hot side interface, heat pipe cold side interface, and the fixed heat pipe for the rejection systems should be recommended for the 1 kW systems. The integrated heat pipe with helium tube hot side interface, pumped coolant cold side interface, and the deployable pumped coolant heat rejection systems should be recommended for the 10 kW systems.

References

- [1] Mason, L. S., "A Comparison of Energy Conversion Technologies for Space Nuclear Power Systems," *Proceedings of the 2018 International Energy Conversion Conference*, AIAA, 2018.
- [2] Gibson, M. A., Oleson, S. R., Poston, D. I., and McClure, P., "NASA's Kilowatt Reactor Development and the Path to Higher Power Missions," *Proceedings of the 2017 IEEE Aerospace Conference*, IEEE, 2017.
- [3] VanderVeer, J. R., "Development of a High Performance Multi-Physics Finite Difference Model for use in a Monte Carlo Simulation with Real World Distributions," *Proceedings of the 2nd Thermal and Fluid Engineering Conference*, Begell, 2017.
- [4] VanderVeer, J. R., Sievers, R., Sickenberger, R., Amato, M., Driscoll, G., and Peterson, A., "Stirling Convertor Based 50-500W Radioisotope Power System Generator Study," *Proceedings of the 2019 IEEE Aerospace Conference*, IEEE, 2019.

- [5] Beard, D., Tarau, C., and Anderson, W. G., "Sodium Heat Pipes for Spacecraft Fission Power Generation," *Proceedings of the 15th International Energy Conversion Engineering Conference*, 2017.
- [6] Lee, K.-L., Tarau, C., and Anderson, W. G., "Titanium Water Heat Pipe Radiators for Space Fission System Thermal Mangement," *Proceedings of the Joint 19th International Heat Pipe Conference and 13th International Heat Pipe Symposium*, 2018.